

September 2022

Click the button
to watch the
assembly video

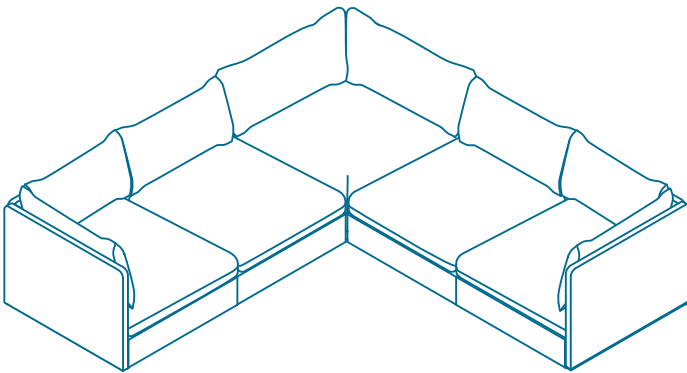

**CORNER SOFA
GETAWAY SOFA**

Korona

What's in the box*:

*Not to scale

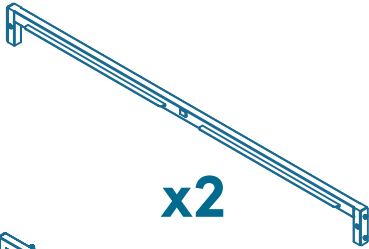

x2



x4
104-9237



x20
104-9177



x12
104-9178



x12
104-9123



x2
104-9176
3 Seater
Only

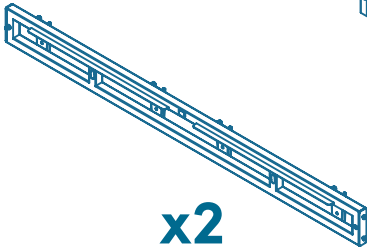

x2

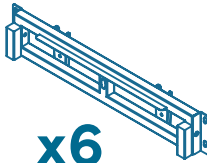

x6

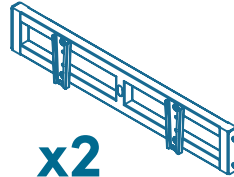

x2



x2
104-9175

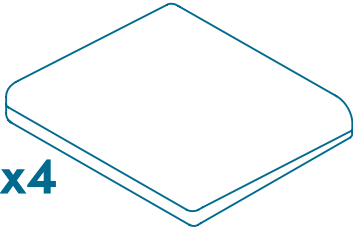

x4

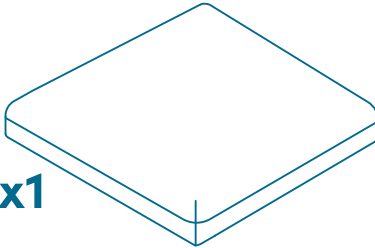

x1

x2



x6

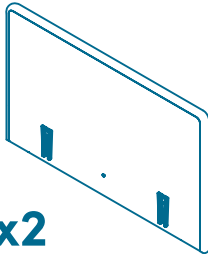
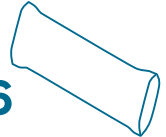

x2



x4

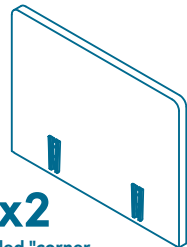

x2
labelled "corner
backrest"

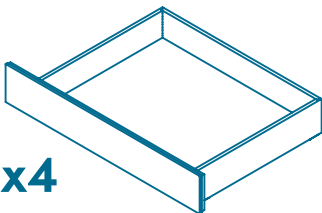

x4

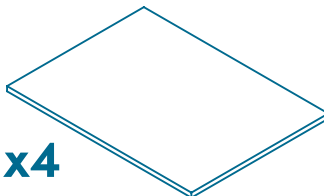

x4

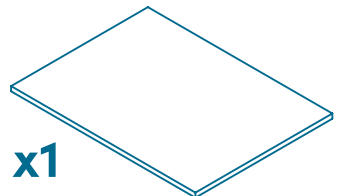

x1
labelled corner

- 1.** Start to build the corner unit. Assemble the metal frame by connecting the four corners together. Make sure brackets are facing outwards and metal ledges are facing inwards.

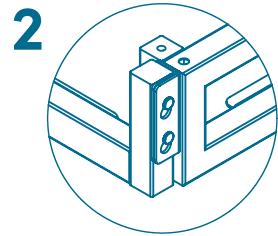
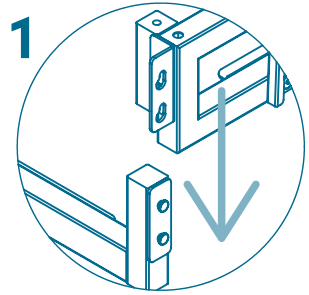
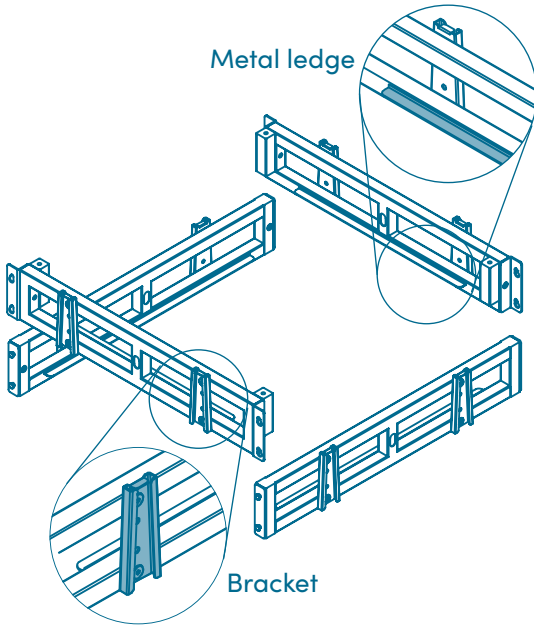

- 2.** Ensure the metal frames are flush with each other before moving to the next step.

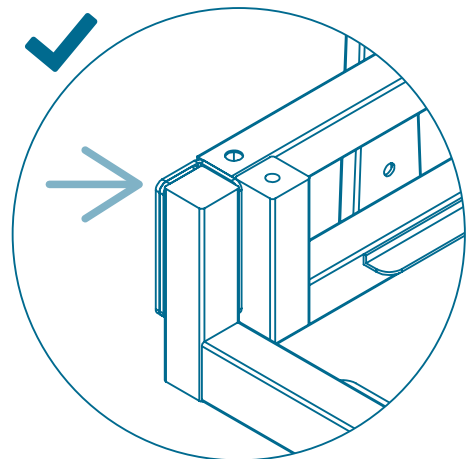
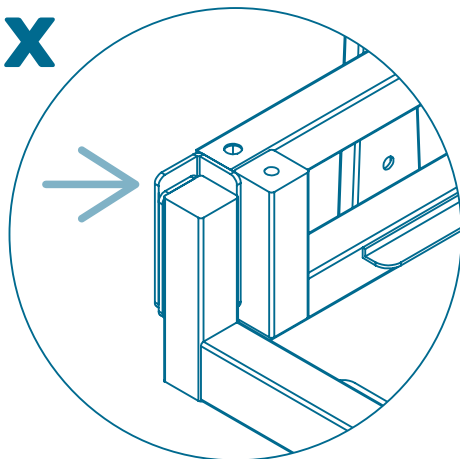

3. Lock the metal frame together by inserting 4x gumnuts into the corners as shown, and tighten completely.

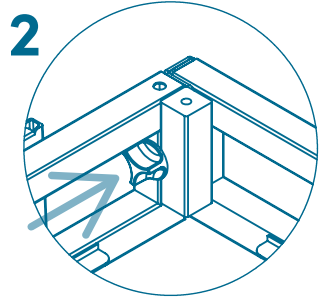
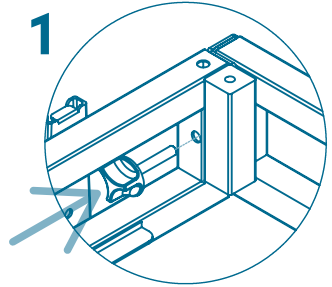
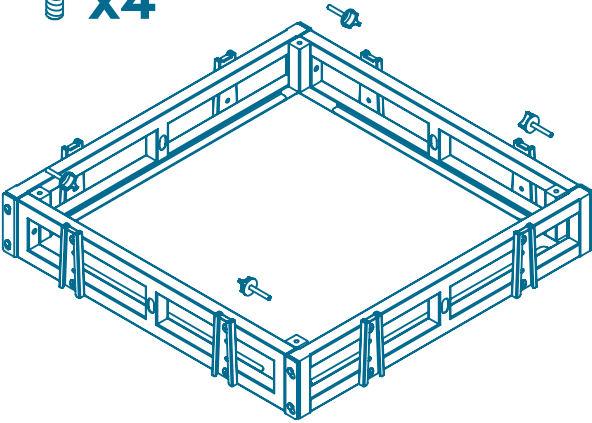

4. Screw on the legs with washers until fully tightened.

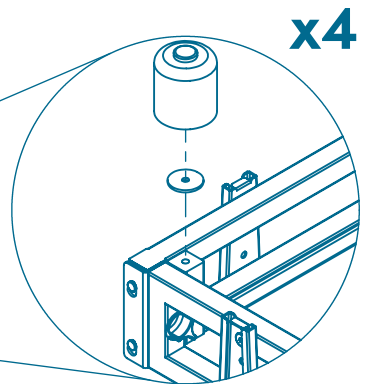
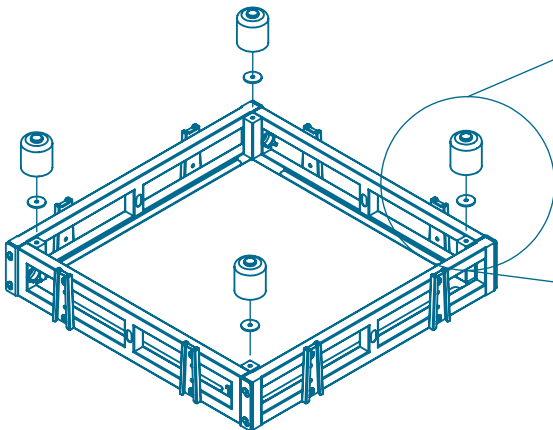

5.

Now its time to assemble therest of your corner sofa
You will make 2 x frames, steps 5-9 will be repeated twice.
Assemble the metal frame by connecting the four corners together. Make
sure brackets are facing outwards and metal ledges are facing inwards.

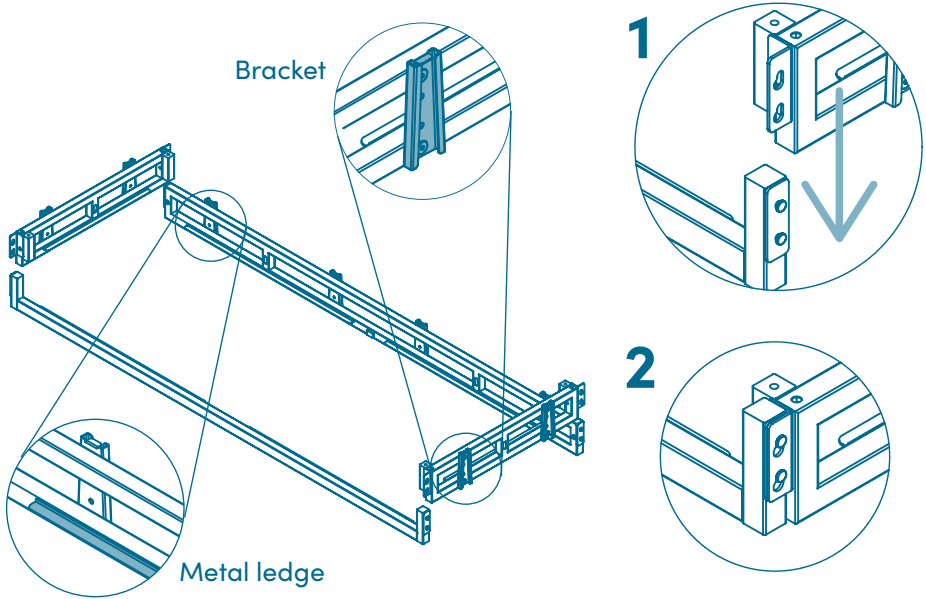

6.

Ensure the metal frames are flush with each other before moving
to the next step.

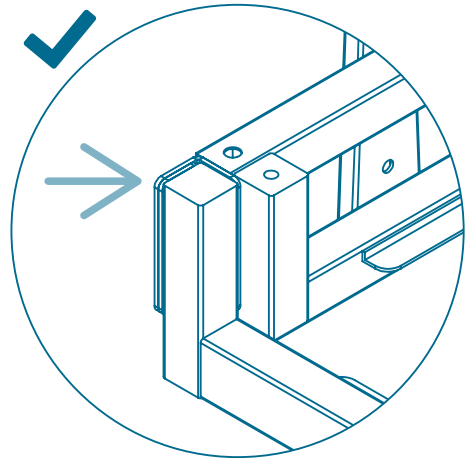
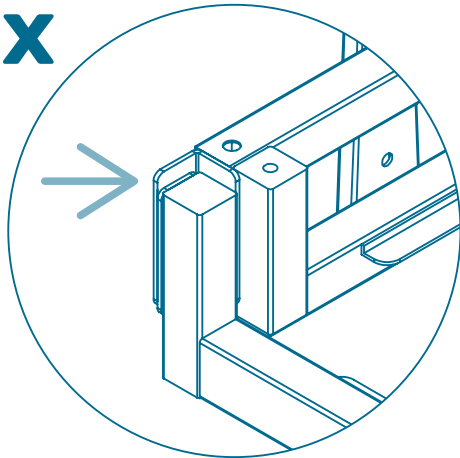

7. Lock the metal frame together by inserting 4 x gumnuts into the corners as shown, and tighten completely.

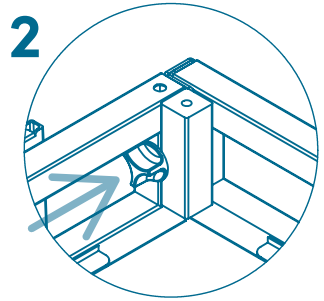
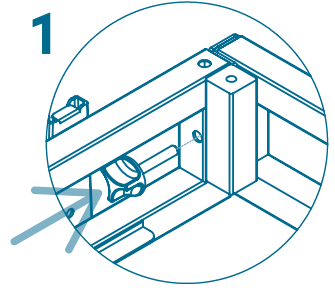
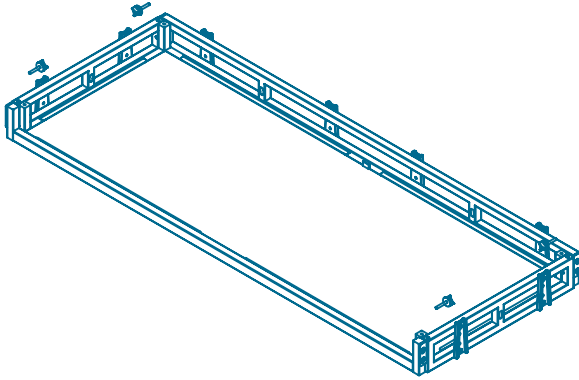

8. Screw on the legs with washers until fully tightened.

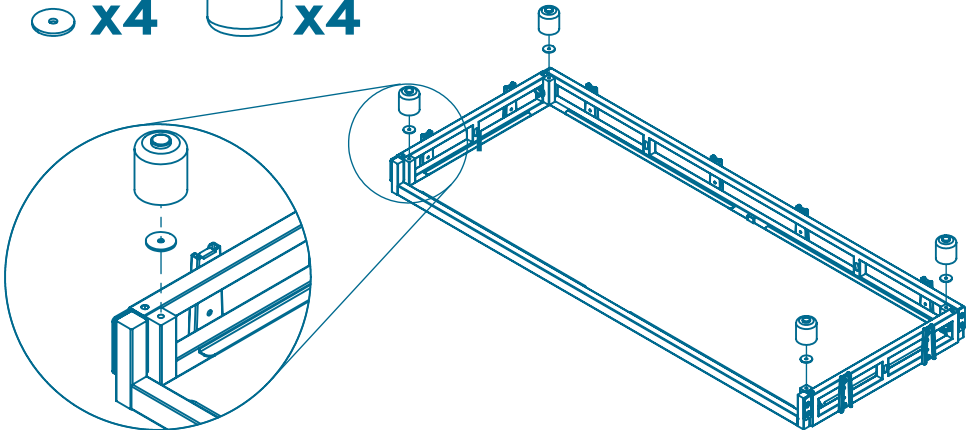

9.

Flip the frame over onto the legs and insert the middle beam.

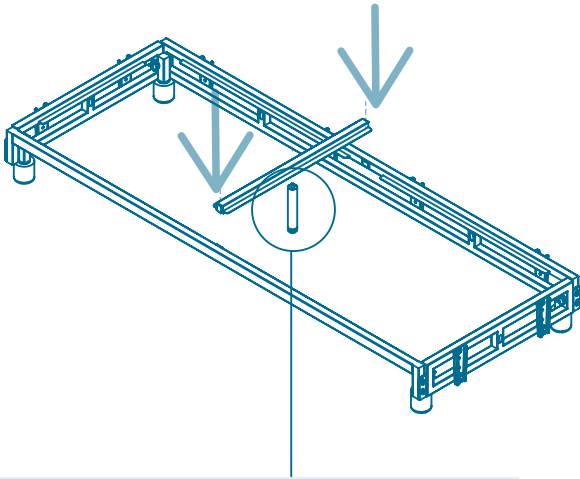

1

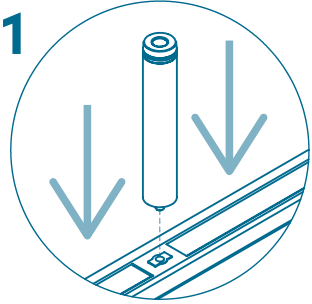

2

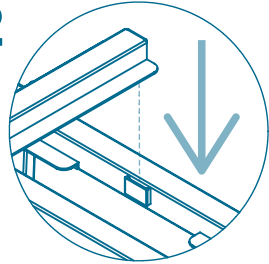

NOTE - The middle leg is only required for 3 seater frames only.

10.

Flip the frame over onto the legs and arrange with the sofa frames as shown.

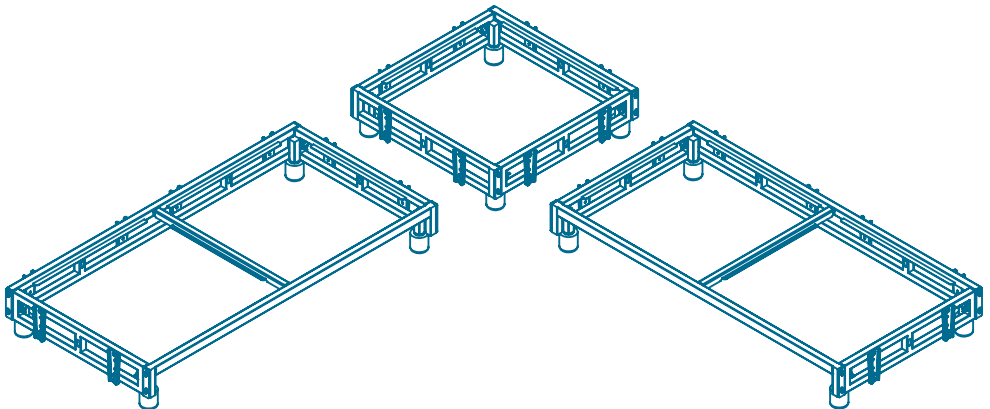

11. Push the frames together so that the metal connection brackets are aligned and insert plastic connection fitting.

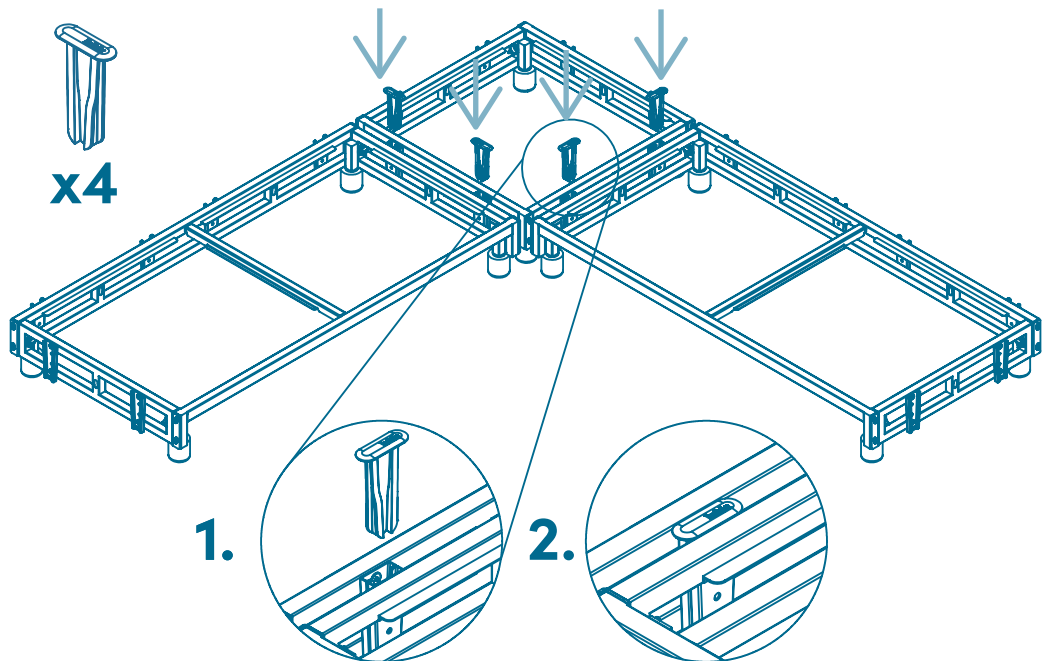

12. Identify the armrests and insert them into the outer brackets and push down fully. Note: the corner backersts are labelled in order to not be confused with the armrests.

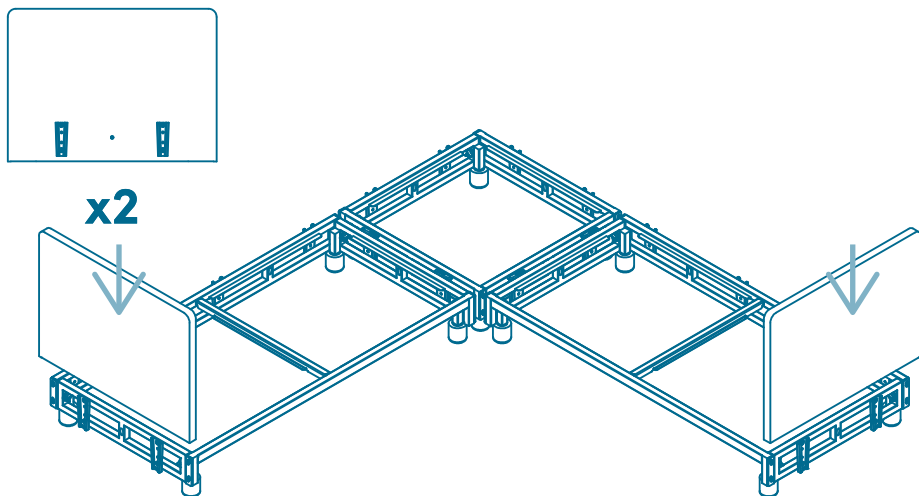

13.

Repeat for the sofa backrests.

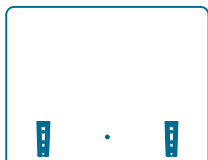

x4

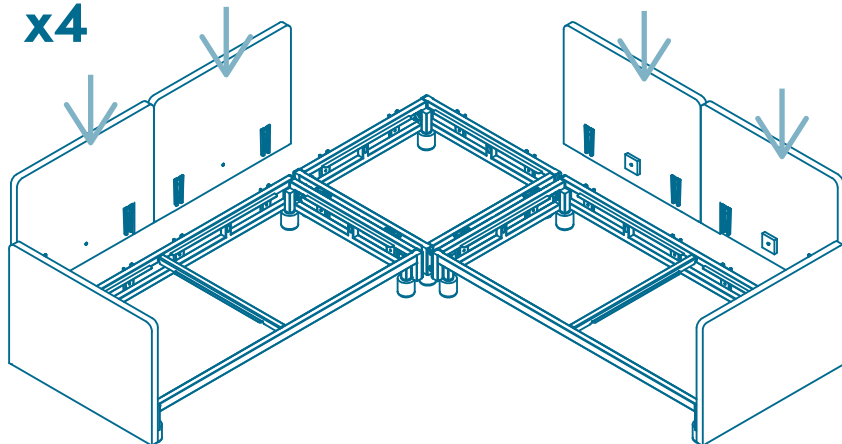

14.

Repeat for the corner backrests. Note, these backrests are labelled in order to not be confused with the armrests.

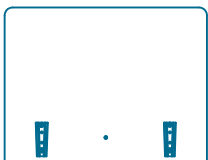

x2

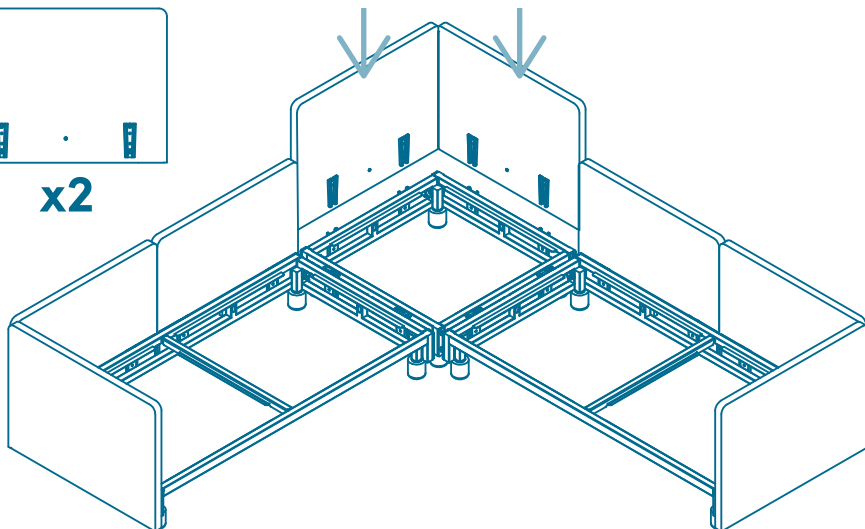

15. Make sure all backrests and armrests have been pushed all the way down. All brackets must be engaged.

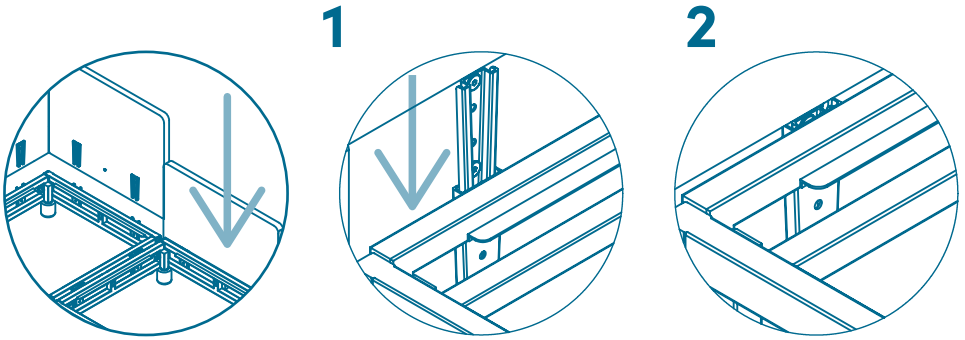

16. Insert the gumnuts through the metal frame into the backrests and armrests, and tighten fully.

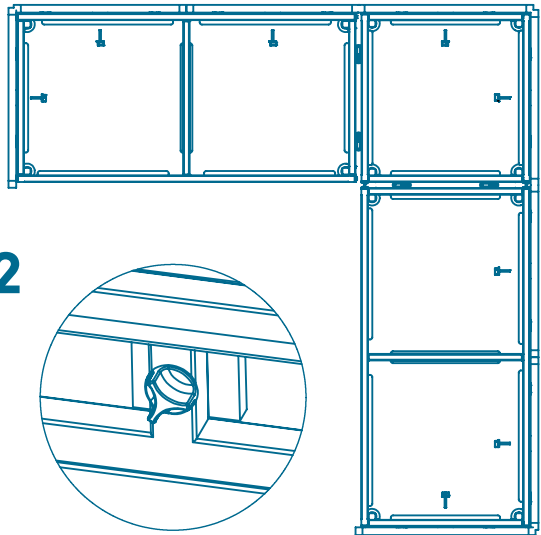

17. Place the sofa inner seat frames onto the metal ledges on the metal frame, making sure to place the label side down.

x5

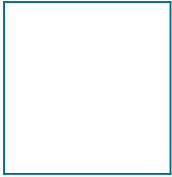

This side up

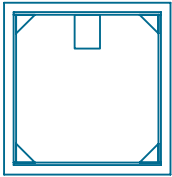

This side down

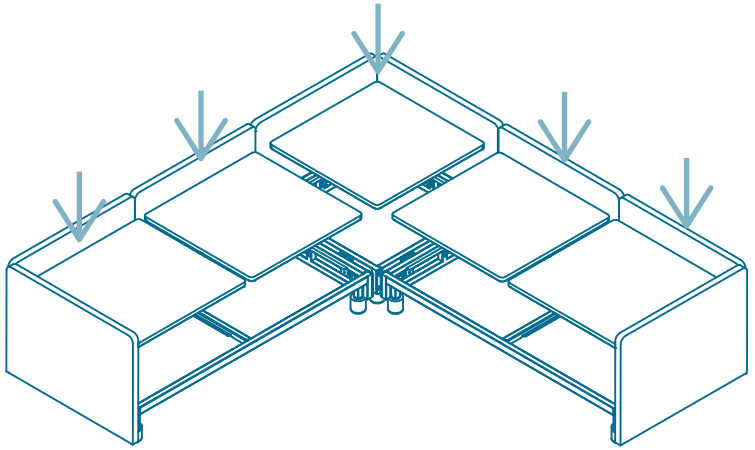

Note: the corner inner seat frame is different and is labelled in order to not be confused with the other sizes.

18. Align and push in the storage boxes under the front metal beam.

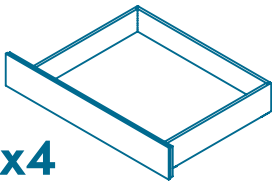

x4

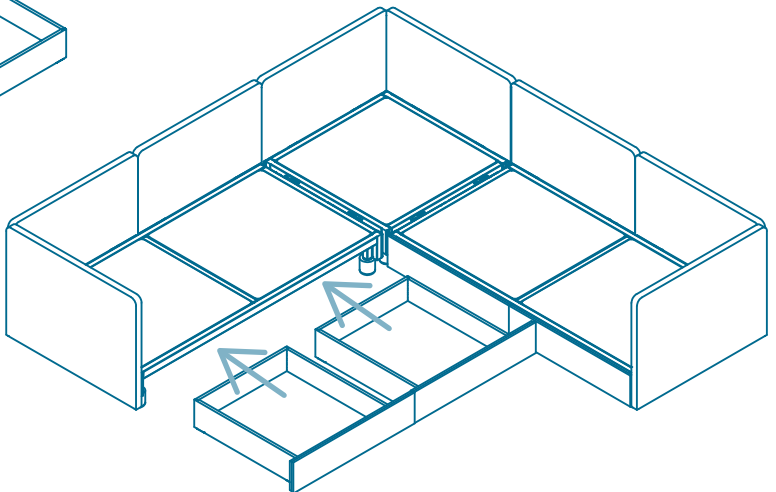

19. Place the seat cushions, backrest cushions, and armrest cushions onto the frame.



Note: Backrest cushions have logo label

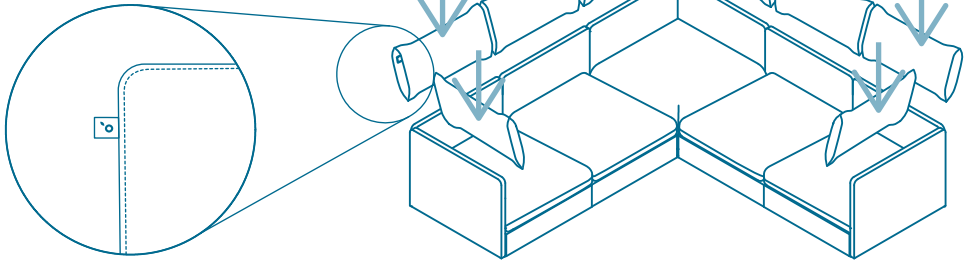

PRODUCT INFORMATION AND CARE

FABRIC

Regular Care (Weekly)

- Vacuum regularly using low suction
- Protect from direct sunlight
- After use, you can fluff the cushions to bring them back to shape

Cleaning

- Remove any spills immediately by gently blotting any liquid stands with a clean cloth.
- Scoop any sauces up before blotting the remaining sauces
- Use a mild detergent to gently remove any loose soilage.
- Do not scrub with a stiff brush.
- Use a clean cloth to blot out any excess liquid.
- Avoid over wetting as this may result in a water mark.

Caution: Pretest the cleaning method on a hidden area of the sofa. If change in colour, or transfer do not continue.

PILLING

Pilling can occur occasionally as a result of normal daily wear and should not be considered a fault. Fibre pills can be removed with a battery operated pilling tool, available from most haberdashery stores.

USING THE SOFA & DRAWERS

Weight Capacity

- Sofa weight capacity: 120kg per seat
- Drawer Weight Capacity: 20kg per drawer

SAFETY AND USE

- Pull and push drawers in a straightwards direction.
- Remember they are drawers not toys.
- Do not jump or stand on the drawers.
- Avoid sitting on the arms or backrest
- Avoid dragging the sofa if you need to move it
- (remember to remove the drawers first).