

**BEDSIDE TABLE
DRAWER ADJUSTMENT**





1. How to adjust the drawer, to make the gaps even. (optional)

Please note:

The hook of the drawer runner always needs to fit into the receiver at the back of the drawer, when doing the adjustment below.

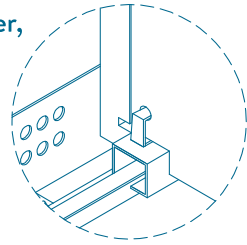
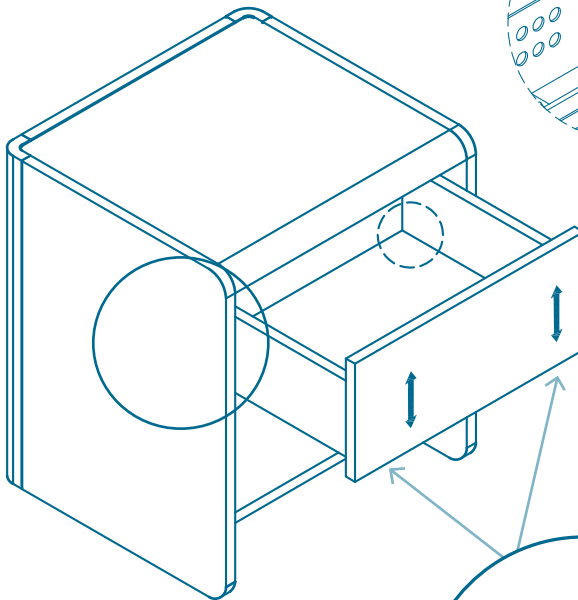

If the drawer's front gap is uneven,
you can adjust the drawer front
up or down by turning the knob.

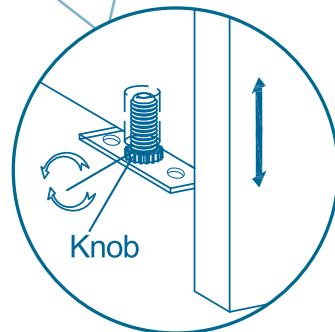



2.

How to remove the drawer.
(optional)

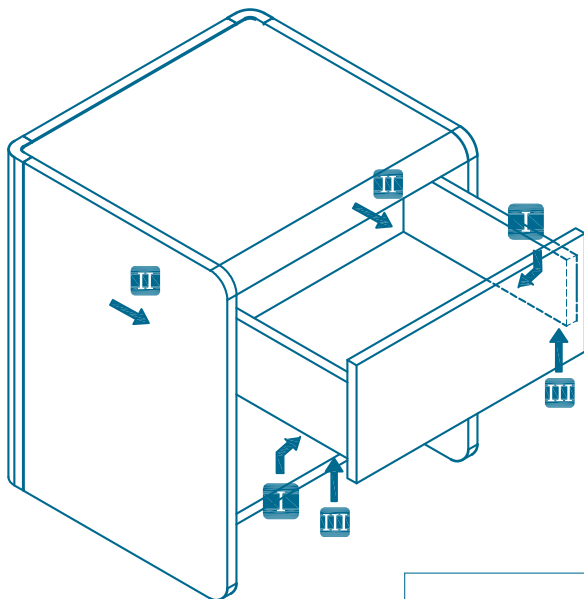

1. Unlock the plastic catch on the drawer runner.

2. Slightly tilt the drawer upwards and slide it out.

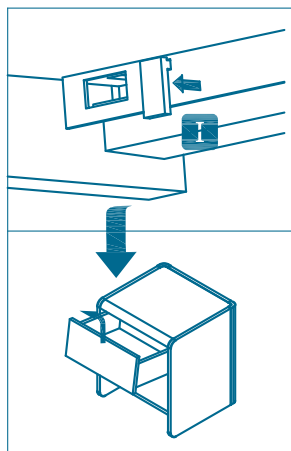



3.

How to reinstall the drawer. (optional)

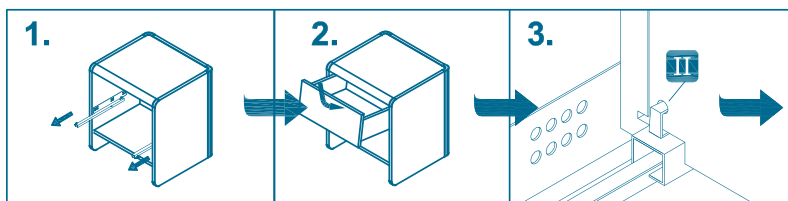

1. Slide the runners out.

2. Slide drawer into cabinet along runners.

3. Fit the runner hook into the drawer's receiver.

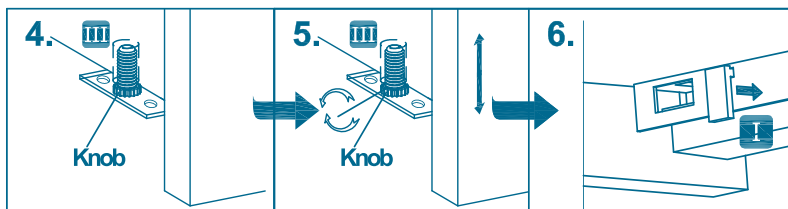

4. Rest knobs into holes under drawer sides.

5. Adjust drawer gap by turning knobs.

6. Lock plastic catch on runners.

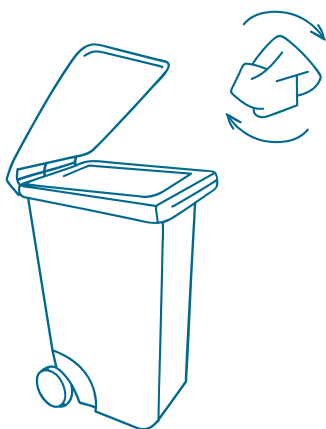

don't forget to recycle

kóala